

CAD FILE:

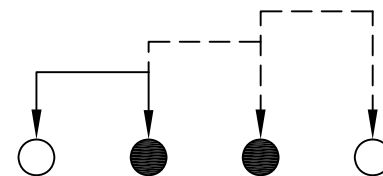

SCHEMATIC (NON-SHORTING)

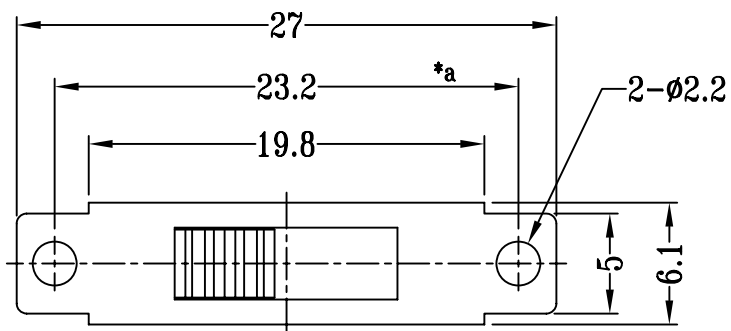
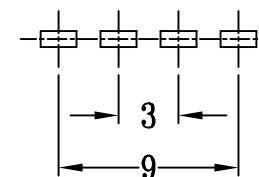
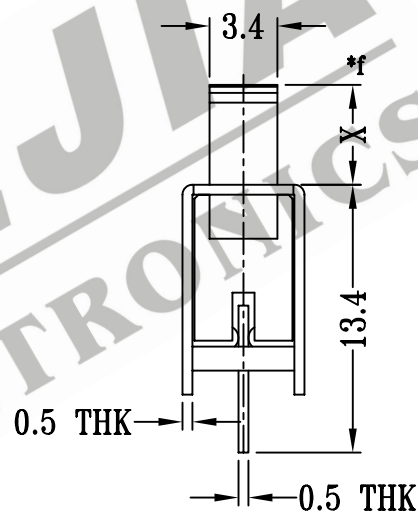
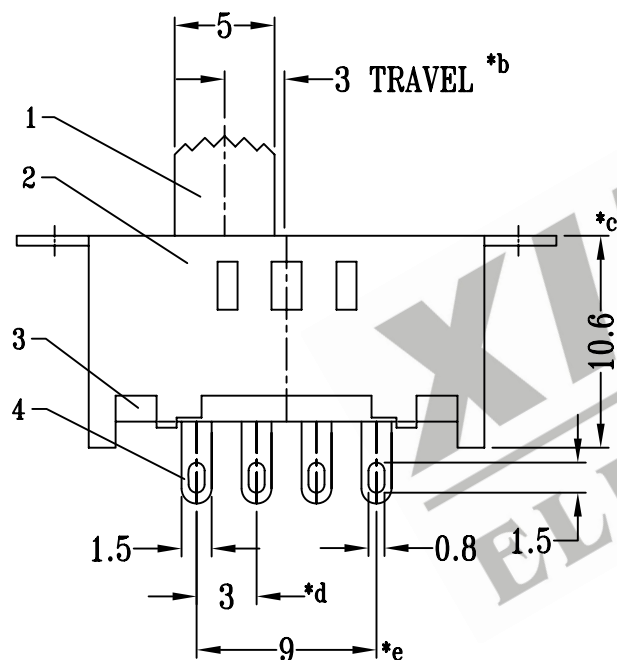

P.C.B LAYOUT

注:带"*"表示关键尺寸(6个)

8					TOLERANCE UNLESS SPECIFIED	SHENZHEN XIEJIA ELECTRONICS CO.,LTD.				
7										
6	SPRING	STEEL WIRE	1	TEMPER	WITHIN: 1.5±0.1mm	ISSUE	DATE	DESCRIPTIONS OF REVISION		APPD.
5	CONTACT CLIP	BRASS STRIP	1	Ag PLATED	OVER : 1.5±0.2mm					
4	TERMINAL	BRASS STRIP	4	Ag PLATED OVER Ni PLATED	TITLE : VERTICAL SLIDE SWITCH		UNIT : mm	DRWG NO.: XJ-DR-SS13F07-00		
3	BASE	PHENOLIC RESIN	1	BLACK						
2	FRAME	STEEL STRIP	1	BLACK	MODEL: SS-13F07		SCALE: 5:2	DWN.	ZHOUYU	2002-7-26
1	KNOB	POM	1	BLACK				CHK'D	FANGYING	2002-7-26
NO.	PARTS	MATERIALS	Q'TY	FINISH	ALL MATERIALS MUST BE COMPLIANT TO ROHS			APPD.	KANGXINAN	2002-7-26